

STOWE TOWNSHIP

555 BROADWAY AVENUE • McKEES ROCKS, PA 15136

PHONE (412) 331-4050

www.stowetwp.net

STREET OPENING AND EXCAVATION PERMIT APPLICATION

OFFICIAL USE ONLY

APPLICATION NO:

APPLICANT MUST SUBMIT TWO (2) COPIES OF APPLICATION & ALL SUPPORTING DOCUMENTS WITH REQUIRED FEES

SECTION 1 APPLICANT INFORMATION

DATE:		
CONTACT LAST NAME:		
FIRST NAME:		
ORGANIZATION NAME:		
MAILING STREET ADDRESS:		
CITY:	STATE:	ZIP:
PHONE:	FAX:	
EMAIL:		

SECTION 2 SCOPE OF WORK INFORMATION

2A - APPROXIMATE LOCATION OF WORK
STREET ADDRESS - START:
STREET ADDRESS - END:

2B - GENERAL NARRATIVE OF WORK

2C - CONSTRUCTION SCHEDULE	
START DATE:	APPROX. COMPLETION DATE:

2D - SIZE OF EXCAVATION			
LENGTH:	FEET	WIDTH: FEET	SQUARE FEET:

**STOWE TOWNSHIP
STREET OPENING AND EXCAVATION PERMIT APPLICATION**

2E - AFFECTED AREAS (check all that apply)		
<input type="checkbox"/> CENTER OF ROAD (Restoration shall be opening repair plus one (1) foot on each side)	<input type="checkbox"/> DRIVING LANE	<input type="checkbox"/> CURB AND/OR EDGE OF ROAD
<input type="checkbox"/> SIDEWALK (Restoration shall be portion of sidewalk removed / joint to joint)		
<input type="checkbox"/> DRIVEWAY (Restoration shall be portion of driveway disturbed)		
<input type="checkbox"/> PUBLIC RIGHT-OF-WAY (Restoration shall be replaced in-kind)		
NOTES: 1. Restoration of all excavated, removed, or disturbed areas shall be per Borough specifications. 2. Final inspection / acceptance of the restoration shall be at the discretion of the Borough.		

**SECTION 3
REQUIRED SUBMITTALS**

<input type="checkbox"/> ONE-CALL PROVIDE SERIAL NUMBER:
<input type="checkbox"/> CERTIFICATE OF INSURANCE INDICATING WORKERS' COMPENSATION AND LIABILITY COVERAGE
<input type="checkbox"/> PERFORMANCE AND MAINTENANCE BONDS
<input type="checkbox"/> APPLICATION AND GUARANTEE FEES (CERTIFIED or CASHIERS CHECK)
<input type="checkbox"/> PLANS OR SKETCH ACCURATELY DEPICTING SCOPE OF WORK

**SECTION 4
FEE CALCULATION / APPLICATION FEE**
(complete all that apply)

4A <input type="checkbox"/> STREET OPENING AND EXCAVATION	\$1.00 per SQ FT of Opening	\$500.00 Minimum Fee
SQ FT: _____	x \$1.00 = \$ _____	> \$500 ? YES <input type="checkbox"/> NO <input type="checkbox"/> IF NO, FEE = \$500.00

4B <input type="checkbox"/> CURB CUT / DRIVEWAY RECONSTRUCTION	\$1.00 per LF of Curb / \$1.00 per SF of Driveway	\$250.00 Minimum Fee
(1) CURB LF: _____	x \$1.00 = \$ _____	(2) DRIVEWAY SF: _____
	(1) + (2) = \$ _____	x \$1.00 = \$ _____
		> \$250 ? YES <input type="checkbox"/> NO <input type="checkbox"/> IF NO, FEE = \$250.00

4C <input type="checkbox"/> SIDEWALK CONSTRUCTION & REPAIR	\$1.00 per SQ FT of Sidewalk	\$100.00 Minimum Fee
SQ FT: _____	x \$1.00 = \$ _____	> \$100 ? YES <input type="checkbox"/> NO <input type="checkbox"/> IF NO, FEE = \$100.00

4D <input type="checkbox"/> PUBLIC RIGHT-OF-WAY DISTURBANCES	\$100.00 FLAT FEE	**REQUIRED**
---	--------------------------	---------------------

TOTAL APPLICATION AND RESTORATION FEES (4A+4B+4C+4D) =	\$ _____
---	-----------------

**STOWE TOWNSHIP
STREET OPENING AND EXCAVATION PERMIT APPLICATION**

OFFICIAL USE ONLY
APPLICATION NO: _____

**SECTION 5
RESTORATION GUARANTEE CALCULATION
(received as Certified Check or Cashier's Check)**

5A BASE REPAIR COSTS	\$4.25 per SQ FT
-----------------------------	-------------------------

SQ FT: _____	x \$4.25 =
--------------	------------

5B PAVEMENT REPLACEMENT	\$2.50 per SQ FT
--------------------------------	-------------------------

SQ FT: _____	x \$2.50 =
--------------	------------

NOTE: Pavement Area = Curb to curb width and twenty-five (25) feet from each end of opening.

5C DRIVEWAY REPLACEMENT	\$12.00 per SQ FT
--------------------------------	--------------------------

CONCRETE DRIVEWAY

SQ FT: _____	x \$12.00 = \$
--------------	----------------

ASPHALT DRIVEWAY

SQ FT: _____	x \$3.00 = \$
--------------	---------------

5C SIDEWALK REPLACEMENT	\$12.00 per SQ FT
--------------------------------	--------------------------

SQ FT: _____	x \$12.00 =
--------------	-------------

5D LAWN REPLACEMENT	\$5.00 per SQ FT
----------------------------	-------------------------

SQ FT: _____	x \$5.00 = \$
--------------	---------------

TOTAL RESTORATION GUARANTEE (5A+5B+5C+5D) =	\$
--	-----------

**SECTION 6
CERTIFICATIONS**

I, the applicant or Authorized Representative, hereby agree to save the Township, its Officers, Engineer, Police, and Agents harmless from any and all costs, damages, and liabilities that may accrue or be claimed to accrue by reason of such work performed under said permit.

APPLICANT CERTIFICATION:

_____	_____
PRINTED NAME	SIGNATURE
_____	_____
ORGANIZATION	DATE
_____	_____
PHONE	EMAIL

**STOWE TOWNSHIP
STREET OPENING AND EXCAVATION PERMIT APPLICATION**

ACKNOWLEDGEMENT – OFFICIAL USE ONLY

YEAR - NO. - REVISION

APPLICATION NUMBER: _____

DATE APPLICATION COLLECTED: _____

APPROVED: YES NO

DATE APPLICATION APPROVED: _____

FEEES RETURNED: YES NO

IF DENIED, DATE RETURNED: _____

AMOUNT OF FEES COLLECTED :
(SECTION 4) _____

DATE FEES COLLECTED: _____

CHECK NO(s): _____

GUARANTEE TYPE: CHECK BOND

AMOUNT OF GUARANTEE COLLECTED:
(SECTION 5) _____

CHECK/BOND DATE: _____

CHECK/BOND NO: _____

DATE GUARANTEE COLLECTED: _____

DATE PERMIT ISSUED: _____

PERMIT NUMBER: _____

NAME OF OFFICIAL/AGENT: _____

SIGNATURE OF OFFICIAL/AGENT: _____

OFFICIAL/AGENT TITLE: _____

DATE: _____

INSPECTION – OFFICIAL USE ONLY

RESTORATION APPROVAL DATE: _____

APPROVED BY: _____

**STOWE TOWNSHIP
STREET OPENING AND EXCAVATION PERMIT APPLICATION**

OFFICIAL USE ONLY
APPLICATION NO:

PLAN/SKETCH OF WORK AREA

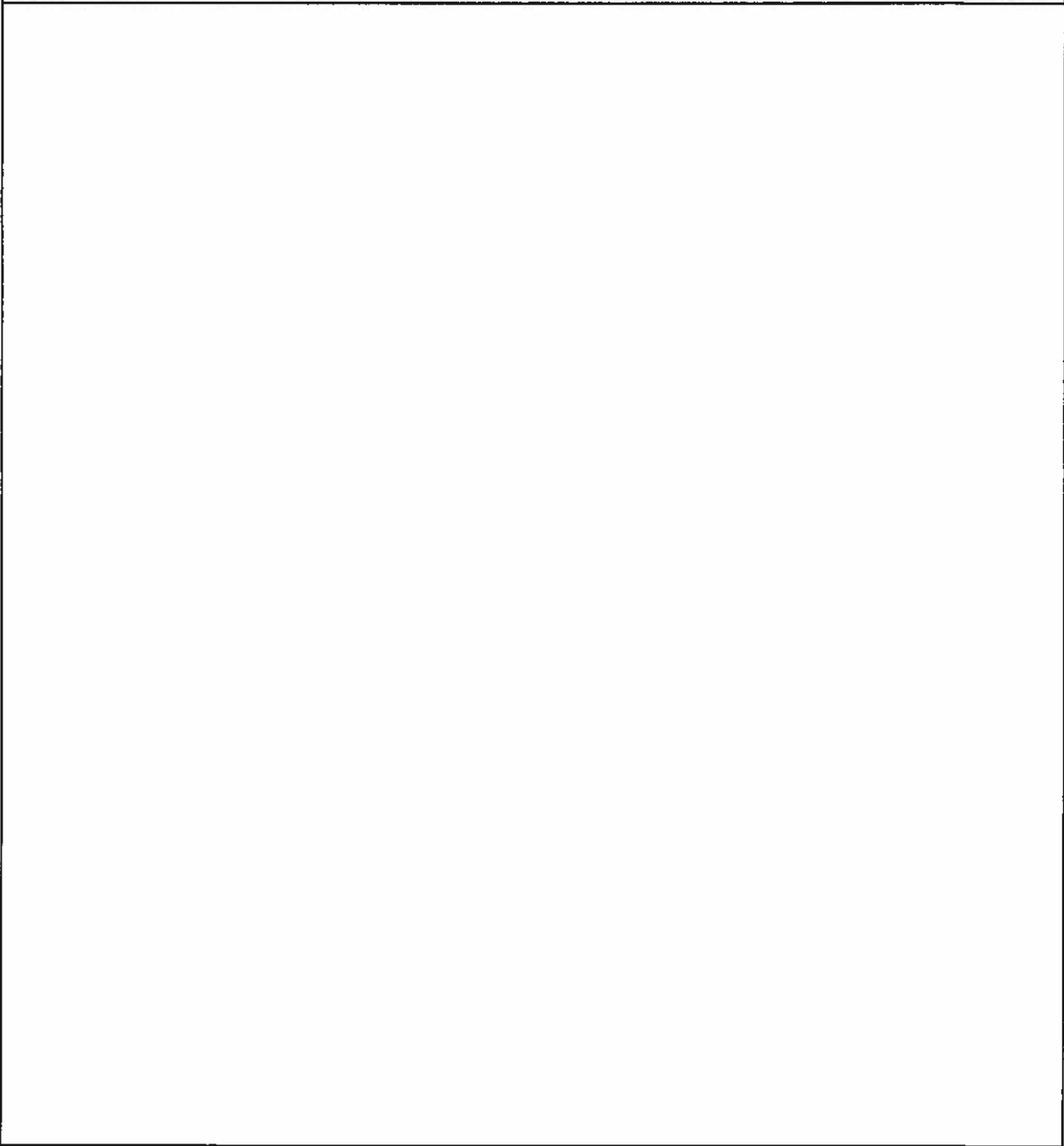

NOTE:

REFERENCE SUPERPAVE PER PA DOT SECTION 409, MIXTURE & DESIGN STANDARDS

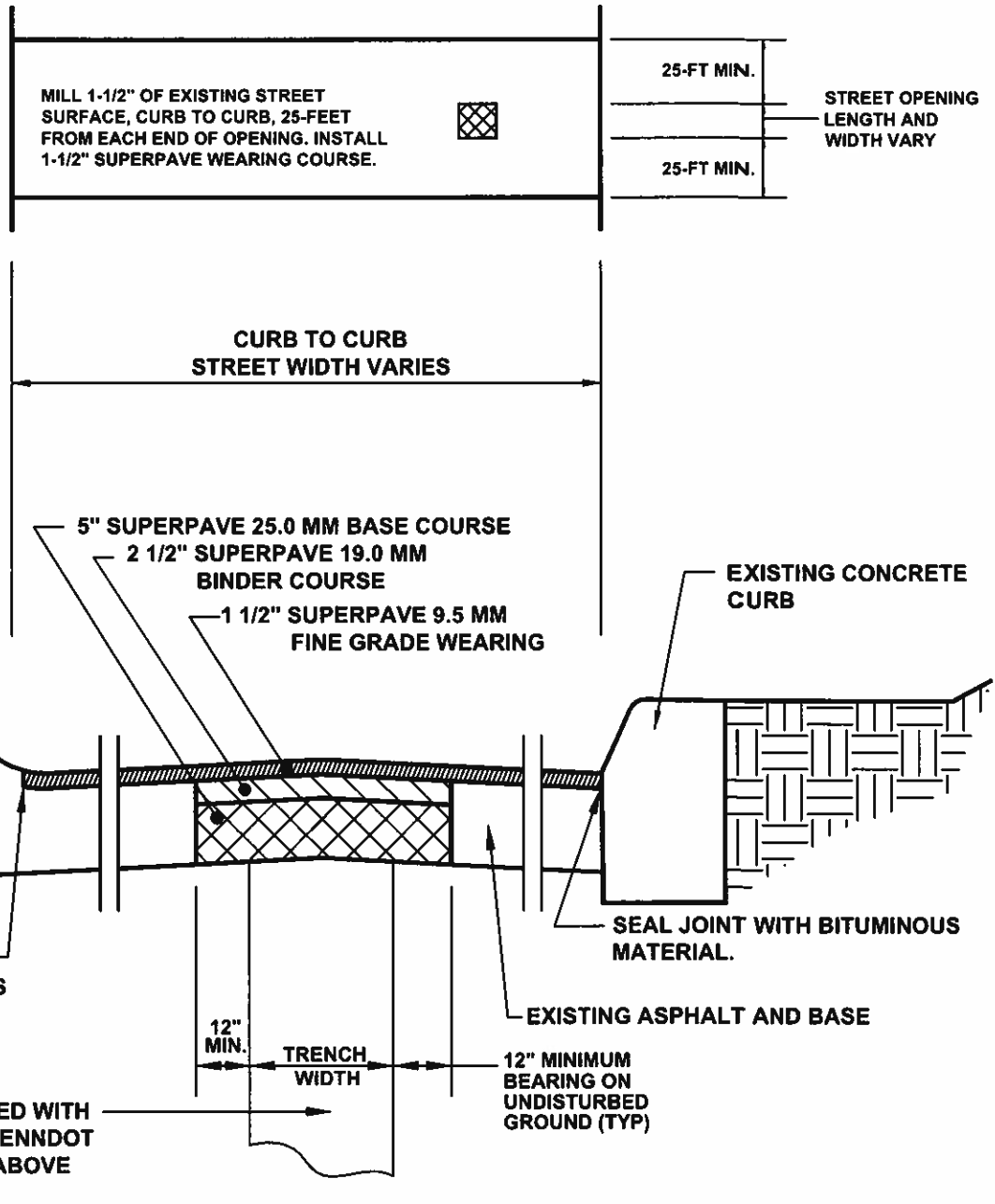

NOTE:

DURING COLD WEATHER WHEN SUPERPAVE MATERIAL IS NOT AVAILABLE FROM THE ASPHALT PLANTS THE TRENCH SHALL BE BACKFILLED WITH 2RC SELECT MATERIAL TO AN ELEVATION WITHIN 3" OF THE ROAD SURFACE. THE TRENCH SHALL THEN BE SURFACED WITH A TEMPORARY PATCH OF COLD PATCH MATERIAL. AS SOON AS THE ASPHALT PLANTS OPEN IN THE SPRING, THE CONTRACTOR SHALL REMOVE THE COLD PATCH AND 2RC MATERIALS AND SAW-CUT THE REQUIRED BENCHES AND THE SUPERPAVE MATERIAL SHALL THEN BE PLACED AND SEALED. THE CONTRACTOR SHALL BE RESPONSIBLE FOR THE MAINTENANCE ON THE TEMPORARY PATCH AND SHALL KEEP A SMOOTH RIDING SURFACE ON THE STREET.

* FOR CONCRETE SURFACED ROADWAYS, THE REQUIREMENTS OF PA DOT PUBLICATION 408 ARE REQUIRED.

NOTE:

WHERE SPECIAL SELECT BACKFILL IS REQUIRED BETWEEN THE PIPE ZONE AND THE SURFACE MATERIAL, THE PIPE ZONE SHALL EXTEND 12" ABOVE THE PIPE REGARDLESS OF PIPE MATERIAL



SELECTED EXCAVATED MATERIAL
MECHANICALLY COMPACTED
MAXIMUM SIZE ROCKS-3"



2B CRUSHED STONE OR
CRUSHED GRAVEL.
1B CRUSHED STONE OR
CRUSHED GRAVEL WITH
APPROVAL BY THE OWNERS
REPRESENTATIVE.



CLASS "C" CONCRETE

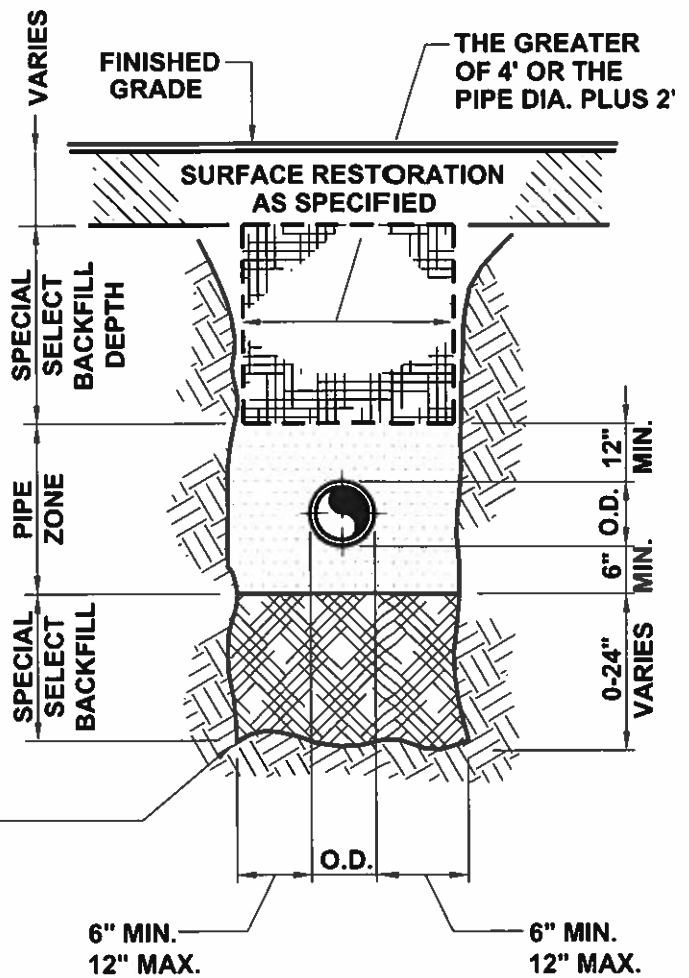

**SPECIAL BACKFILL
DETAIL 2-002 A**

WHERE EXCAVATION EXPOSES THE BOTTOM OF PROPOSED TRENCHES WHERE VERY SOFT OR OTHER UNSTABLE PIPE FOUNDATION MATERIALS EXIST, THE CONTRACTOR WILL BE DIRECTED TO OVERCUT OR STABILIZE / OVERCUT AND THE CONTRACTOR SHALL BE COMPENSATED FOR THE ADDITIONAL EXCAVATION IN ACCORDANCE WITH THE PROVISIONS SPECIFIED IN THE GENERAL CONDITIONS.

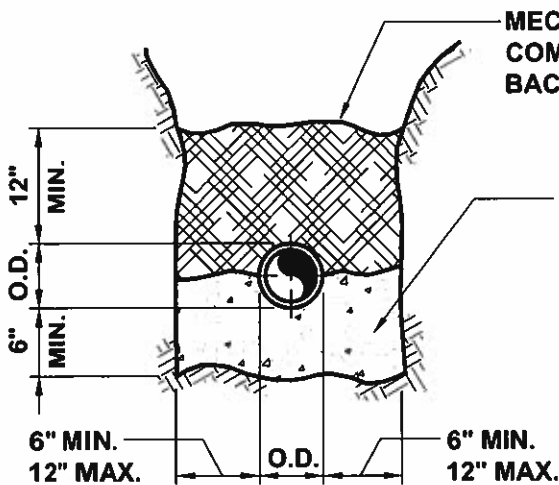

**TYPICAL CONCRETE CRADLE
DETAIL 2-002 B**

6" MIN. THICKNESS CONC. ENCASEMENT
POURED AGAINST UNDISTURBED EARTH
CLASS "C" CONCRETE

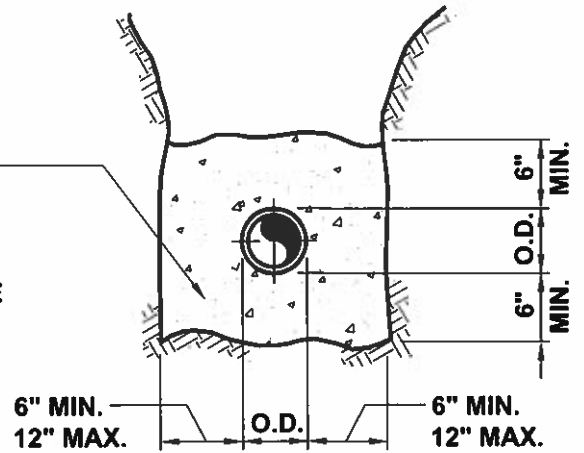

**TYPICAL CONCRETE ENCASEMENT
DETAIL 2-002 C**

<p>KLH ENGINEERS, INC. 5173 Campbells Run Road Pittsburgh, PA 15205</p>		<p>TRENCH DETAILS</p>
<p>Not to scale</p>	<p>April 2010</p>	<p>Standard Detail SD-2-002</p>

MATCH GRADE TO TRENCH. ALL DEPRESSIONS
OUTSIDE TRENCH WIDTH TO BE RAISED IN
ACCORDANCE WITH CONTRACT SPECIFICATIONS

EXISTING BRICK ROADWAY SURFACE

REPLACE BRICK BY HAND

DRY MIX 1 PART PORTLAND CEMENT TO 6 PARTS SAND. SWEEP
INTO BRICK JOINTS, LIGHTLY DAMPEN BRICK SURFACES.

2" HARD CLEAN
SILICA SAND

6" CLASS 'A'
CONCRETE

12"

1B CRUSHED STONE OR
GRAVEL FOR FULL DEPTH
OF TRENCH

SEE PIPE ZONE DETAILS AND
PIPE BEDDING DETAILS

OWNER'S REPRESENTATIVE WILL DESIGNATE DEPRESSED AREAS OUTSIDE TRENCH
AREA TO BE RAISED. CONTRACTOR TO HAND REMOVE BRICK, ESTABLISH GRADE
UTILIZING SAND, RELAY BRICK IN ACCORDANCE WITH CONTRACT DOCUMENTS.
PAYMENT FOR DEPRESSED AREAS WILL BE BY SQUARE YARD AS DETERMINED BY
OWNER'S REPRESENTATIVE.

KLH ENGINEERS, INC. 5173 Campbells Run Road Pittsburgh, PA 15205		RESTORATION OF BRICK SURFACE
Not to scale	April 2010	Standard Detail SD-2-073

NOTE:

**REFERENCE SUPERPAVE
PER PA DOT SECTION 409
MIXTURE & DESIGN STANDARDS**

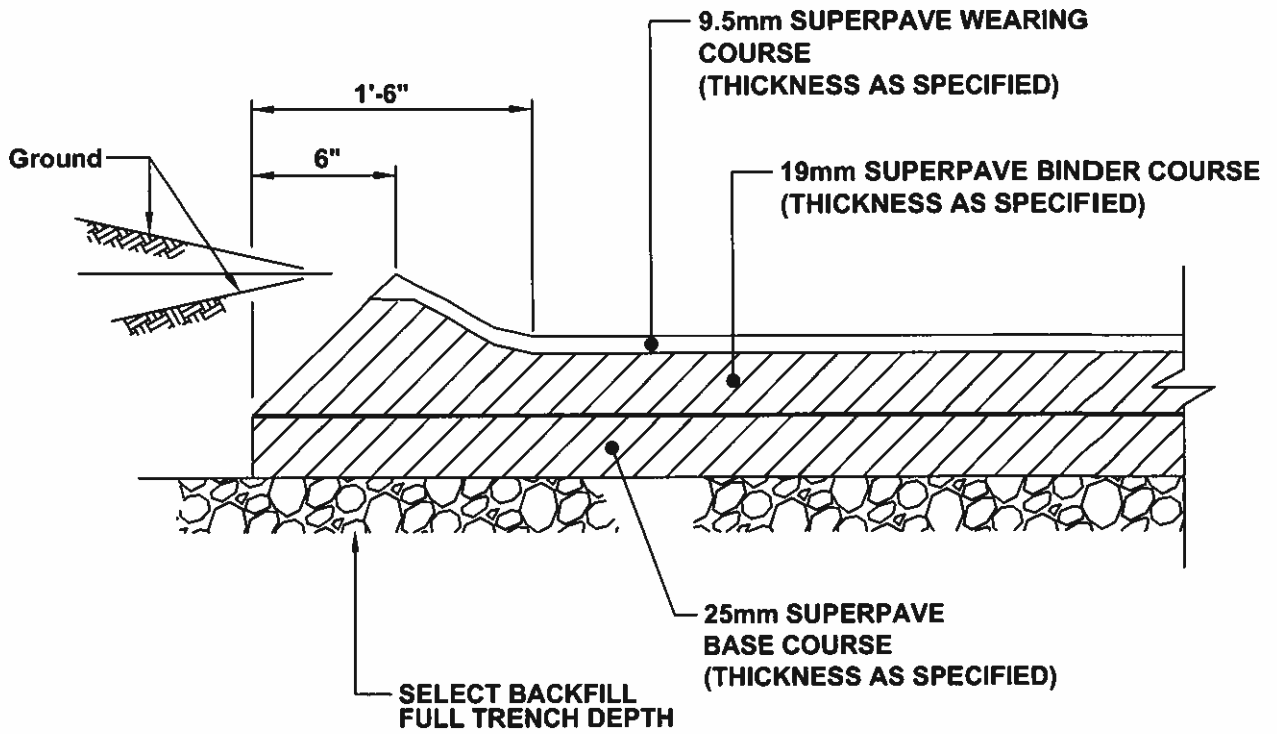

KLH ENGINEERS, INC. 5173 Campbells Run Road Pittsburgh, PA 15205		ASPHALT WEDGE CURB RESTORATION
Not to scale	August 2014	Standard Detail SD-2-077

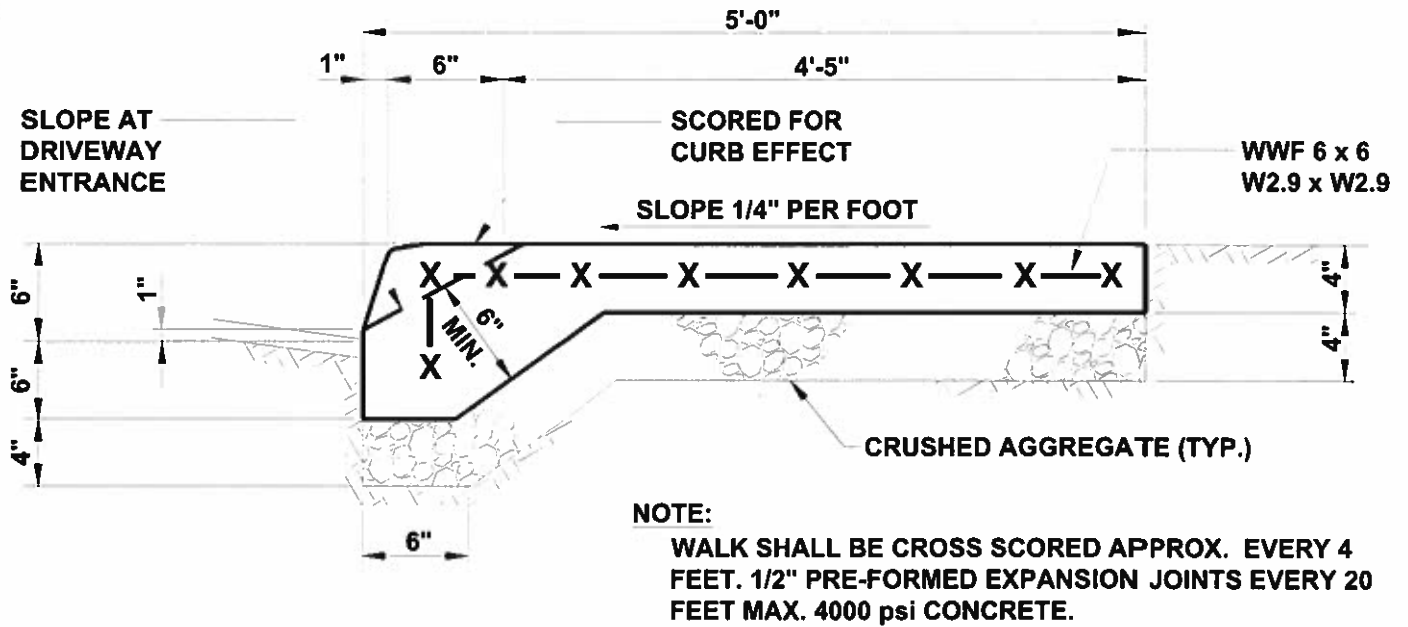

TYPICAL CURB AND SIDEWALK DETAIL

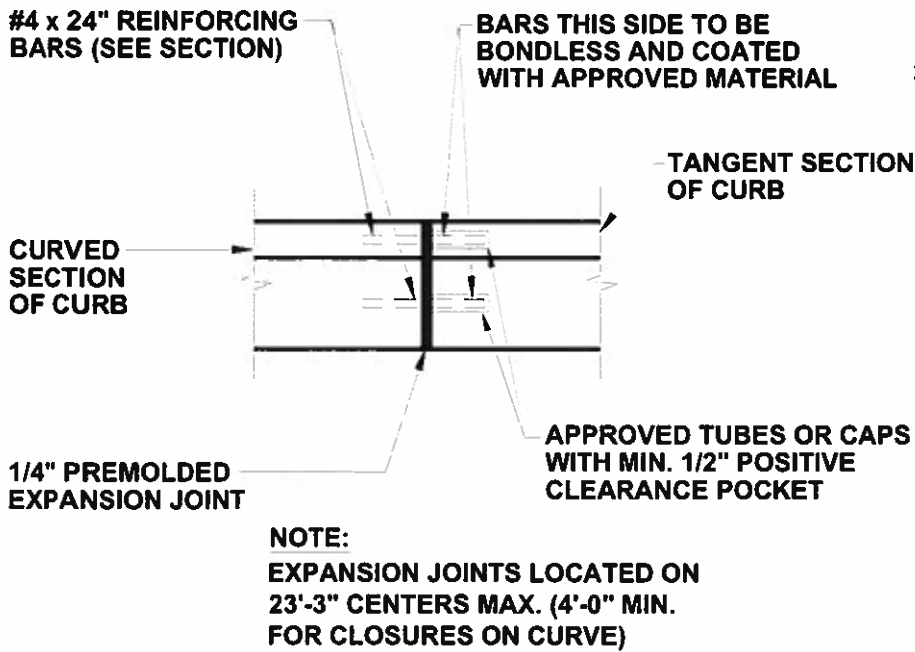

POINTS OF CURVATURE

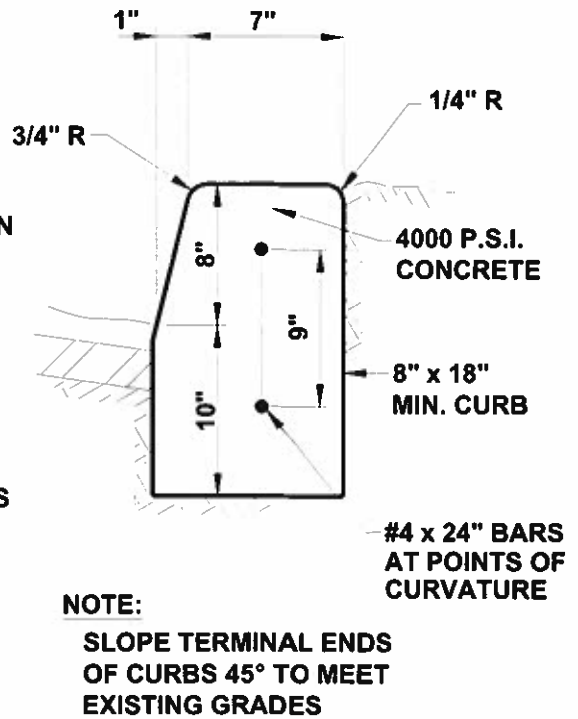

SECTION

TYPICAL CURB DETAILS

<p>KLH ENGINEERS, INC. 5173 Campbells Run Road Pittsburgh, PA 15205</p>		<p>CURB AND SIDEWALK DETAIL</p>
<p>Not to scale</p>	<p>April 2010</p>	<p>Standard Detail SD-2-079</p>

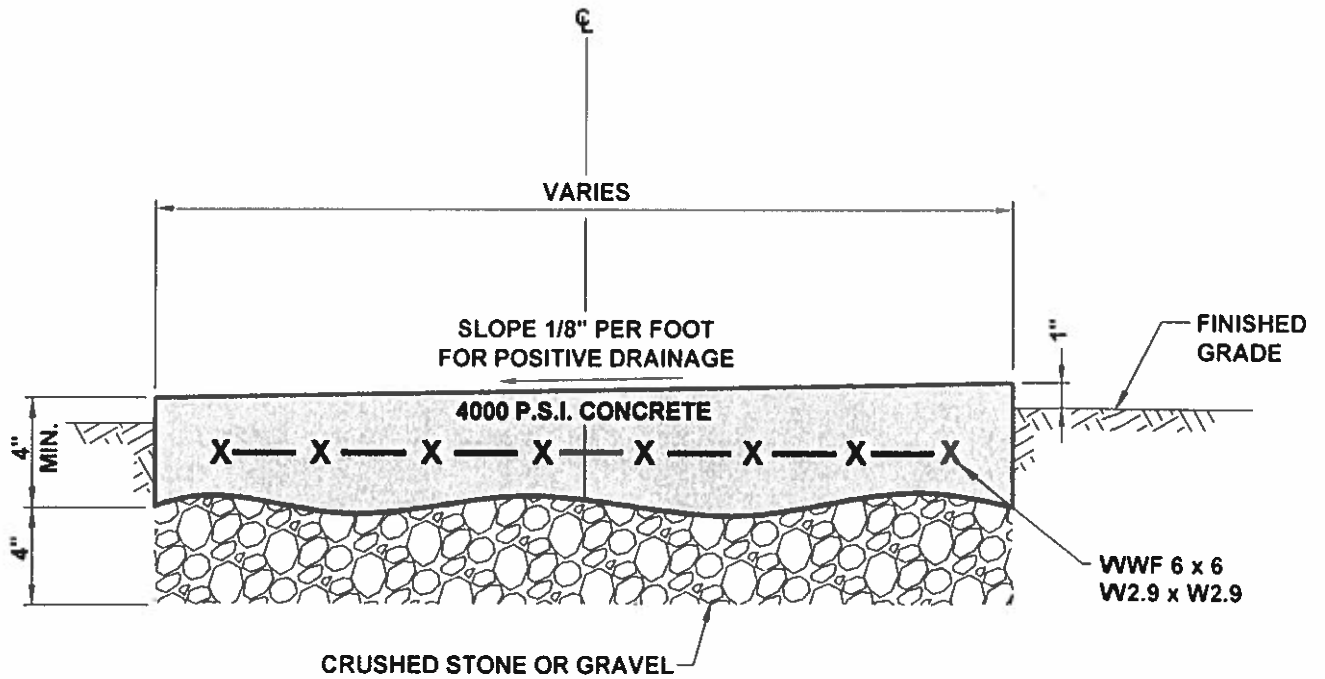

NOTES:

1. SAME THICKNESS OF CONCRETE, BASE AND WEARING SURFACE SLOPE TO BE MAINTAINED FOR WIDER OR NARROWER WALK.
2. WALK SHALL BE CROSS SCORED APPROXIMATELY EVERY 4 FEET 1/2" PRE-FORMED EXPANSION JOINTS EVERY 24 FEET. THE PRE-FORMED EXPANSION JOINT SHALL BE SEALED WITH SIKAFLEX 1cSL OR APPROVED EQUAL.

KLH ENGINEERS, INC. 5173 Campbells Run Road Pittsburgh, PA 15205		CONCRETE WALKWAY
Not to scale	May 2016	Standard Detail SD-2-080

**STOWE TOWNSHIP
ALLEGHENY COUNTY, PENNSYLVANIA
ORDINANCE NO. 1014**

AN ORDINANCE OF THE BOARD OF COMMISSIONERS OF THE TOWNSHIP OF STOWE, ALLEGHENY COUNTY, PENNSYLVANIA, AMENDING CHAPTER 592 (“STREETS AND SIDEWALKS”) ARTICLE III (“OPENINGS AND EXCAVATIONS”) AND ARTICLE IV (“SIDEWALK MAINTENANCE AND CONSTRUCTION”) TO MODERNIZE AND UPGRADE THE SPECIFICATIONS, APPLICATION PROCESS, MAINTENANCE WORK REQUIREMENTS, AND VIOLATIONS AND PENALTIES FOR OPENING OR EXCAVATION WORK ON ANY SURFACE OF ANY STREET OR RIGHT-OF-WAY DEDICATED FOR PUBLIC USE IN THE TOWNSHIP OF STOWE.

WHEREAS, the Board of Commissioners of the Township of Stowe, desires to enhance the health, safety, and welfare of the residents in the Township, and have determined that amending this Chapter and increasing the fees, fines and penalties are necessary to address this issue.

NOW, THEREFORE, be it ORDAINED and ENACTED by the Board of Commissioners of the Township of Stowe as follows:

Section 1. Ordinance 1014, Chapter 592, Article III, Sections 592-14 through 592-28 shall be amended as follows, and shall be renumbered to be Sections 592-14 to 592-37:

§ 592-14 – Definitions.

As used in this article, the following terms shall have the meanings indicated:

AS-BUILT PLAN – A drawing showing the final as-built location, elevation and/or depth, size and materials of all completed public and private improvements as well as all easements.

CARTWAY – That portion of the street right-of-way surfaced for vehicular use.

COMMISSIONERS – The Board of Commissioners for Stowe Township

CONSTRUCTION STANDARDS – The construction standards for streets, stormwater management facilities, sanitary sewer systems, pedestrian circulation, driveways and other facilities.

DEVELOPER – Any landowner, not a public utility company, agent of such landowner, including the landowner’s contractor, or resident or superintendent or tenant with permission of such landowner, who constructs or causes to be constructed any public or private improvements anywhere in the Township not under a contract.

DRIVEWAY – A private area used exclusively for circulation and ingress and egress to a street by the owner or owners of visitors of the lot.

DWELLING, SINGLE Family – A residential building containing one dwelling unit occupied by one family and which is the only principal building on the lot.

EMERGENCY - Any unforeseen circumstance or occurrence, the existence of which constitutes a clear and immediate danger to persons or properties.

ENGINEER – The Township Engineer, who is charged with the design and inspection of the work and with determining the quantities of materials and labor to be paid for. During the execution of the work, the “Engineer” shall also be interpreted to mean the assistant, inspector or other representative acting within the authority given. The Engineer is to be considered an agent of the Township.

FINANCIAL SECURITY – A corporate bond, letter of credit, or escrow account from a surety or a financial institution acceptable to the Township, naming the Township as obligee in forms specified herein.

LANDOWNER – The legal or beneficial owner or owners of a lot, including the holder of an option or contract to purchase (whether or not such option or contract is subject to any conditions), a lessee (if he is authorized under the lease to exercise the rights of the landowner) or other persons having a proprietary interest of the lot.

PERMITTEE – Any person who has been issued a permit and is obligated to fulfill all the terms of this article. [Added 2-12-2013 by Ord. No. 963]

PUBLIC IMPROVEMENTS – A street, sidewalk, walkway, gutter, curb, sewer, waterline, streetlight, street sign or related facility to be dedicated to or maintained by the Township.

PUBLIC UTILITY COMPANY – Any company subject to the jurisdiction of and control by the Pennsylvania Public Utility Commission or franchised cable television company.

RESTORATION GUARANTEE FEE - The amount of the financial security, in a form acceptable to the Township Solicitor and in compliance with the requirements of this Part, to guarantee faithful performance of the work authorized by a permit granted. The fee shall be equal to the schedule as stated in the fee calculation. Pavement replacement shall be calculated as the future cost to mill and resurface the roadway, curb to curb, 25 feet from each end of the opening. The fee will be established by Township Commissioners by resolution and revised from time to time.

SIDEWALK – A walk for pedestrians, constructed to the standards set forth herein.

SPECIFICATIONS – Those portions of the contract documents consisting of written technical descriptions of materials, equipment, construction systems, standards and workmanship as applied to the work.

STREET – A public street, public easement, right-of-way, public highway, public alley, public sidewalk, public way or public road accepted or maintained by the municipality or open for travel and use by the public, whether or not so accepted or maintained, including the entire area within the right-of-way thereof.

TOWNSHIP – The Township of Stowe, Allegheny County, Pennsylvania.

UTILITY – A public service, including, but not limited to, electric service, gas service, water service, phone service and cable TV service.

WALKWAY – A walk for pedestrians, constructed to the standards set forth herein.

§ 592-15 – Permit Required.

The opening or excavation of the surface of any street or right-of-way dedicated for public use of the Township of Stowe is hereby prohibited unless a permit is obtained for that purpose in the manner hereinafter described. Such permit shall be granted by the Township Secretary of said Township when the person, firm or corporation applying for such permit files an application with the said Secretary in compliance with the provisions of this article and pays the moneys hereinafter stated; provided, however, that nothing herein contained shall be construed to permit the issuing of a permit for the making of a tunnel under any street or right-of-way dedicated for public use in the Township. As the permittee, the utility company or contractor shall be fully liable for all work done or caused by him, and for all damage done by him or the utility itself and shall accept full responsibility for restoration and repair to a condition equal to or better than existing initially. The contractor shall be responsible for Act 38 requirements of 1991 (PA One Call) before beginning any excavation.

§ 592-16 – Adherence to Terms of Permit.

No permittee shall perform any of the work authorized by such permit in any amount greater than that specified in such permit. An application for a new permit shall be deemed to cover any such additional work, as may be added pursuant to the issuance of an amended permit within the limit specified herein.

§ 592-17 – Time Frame for Commencement of Work.

Work for which a permit has been issued shall commence within 30 days after issuance of the permit. If not so commenced, the permit shall be terminated automatically unless the permittee applies for an extension of time within which to commence work. If such an extension is granted, the original permit shall remain in force for the period of time specified in the extension. Permits which terminate by reason of failure to commence work within 30 days after issuance thereof or within any extension of time granted hereunder may be renewed only upon the payment of an additional permit fee as originally required.

§ 592-18 – Permits Nontransferable.

Permits are not transferable from one person to another, and the work shall not be performed in any place other than the location specifically designated in the permit.

§ 592-19 – Expiration of Permits.

Every permit shall expire at the end of the period of time which shall be set out in the permit. If the permittee shall be unable to complete the work within the specified time, he or she shall, prior to the expiration of the permit, present, in writing, to the Township Secretary a request for an extension of time setting forth therein the reasons for the requested extension. If the Township of Stowe finds that the failure to complete the work under the permit within the time specified therein was due to circumstances reasonably beyond the control of the permittee and that an extension of time to complete the work under the permit is necessary and not contrary to the public interest, the permittee may be granted additional time for the completion of the work.

§ 592-20 – Cuts Made by Township Utilities.

All street openings required by utilities owned and/or operated by the Township shall be made and restored under the direction and supervision of the Township of Stowe. The permit, fee, deposit, insurance and bond requirements of this Part shall not be applicable to any openings made by Township-owned and/or operated facilities.

§ 592-21 – State and County Highways.

The provisions of this Part shall not be applicable in those instances where the street or highway is maintained by the Commonwealth of Pennsylvania or by the County of Allegheny; provided, however, that any person applying for a permit to do work within the right-of-way of a street or highway maintained by the Commonwealth of Pennsylvania or by the County of Allegheny which would otherwise require a permit under the terms of this Part shall notify the Township Secretary at the time that said application is made and at the time that the work under any permit issued pursuant to said application is begun, so that proper safety precautions may be taken by the Township during the continuation of said work.

§ 592-22 – Right to Use Streets.

Every permit shall be granted, subject to the right of the Township, or of any other person entitled thereto, to use the street for any purpose for which such street may lawfully be used not inconsistent with the permit.

§ 592-23 – Revocation of Permit.

- A. Any permit may be revoked by the Township of Stowe, after written notice to the permittee for:
 - i. Violation of any condition of the permit or of any provision of this Article.
 - ii. Violation of any other applicable provision of the Township Code or any other applicable ordinance, regulation or statute.
 - iii. The existence of any condition or the doing of any act constituting or creating a nuisance or endangering the life or property of others.
- B. A permittee shall be granted a period of 3 days from the date of the notice to correct the violation and to proceed with the diligent prosecution of the work authorized by the permit before said permit is revoked.
- C. Written notice of any such violation or condition shall be served upon the permittee or his or her agent engaged in the work. The notice shall contain a brief statement of the reasons for revoking the permit. Notice may be given either by personal delivery thereof to the person to be notified or by certified or registered United States mail addressed to the person to be notified.
- D. When any permit has been revoked and the work authorized by the permit has not been completed, the Township of Stowe shall do or cause to be done such work as may be necessary to restore the street or part thereof to as good a condition as before the opening was made. All expenses incurred by the Township shall be recovered from the deposit or bond of the permittee has made or filed with the Township.

§ 592-24 – Application for permit.

It shall be the duty and responsibility of the Applicant to:

- A. Submit written applications for the opening of any street or right of way with the Township of Stowe on such form as he or she shall prescribe. No work shall commence until the

Township Secretary has approved the application and plan and issued a permit, and until the permittee has paid and provided all required fees, deposits, certificates and bonds.

- B. Furnish, in duplicate, a plan showing the work to be performed under said permit. One copy of such plan shall be returned to the applicant at the time the permit is granted.
- C. Agree to save the Township, its officers, employees and agents harmless from any and all costs, damages and liabilities which may accrue or be claimed to accrue by reason of any work performed under said permit. The acceptance of a permit shall constitute such an agreement by the applicant whether the same is expressed or not.

§ 592-25 – Permit application fees

It shall be the duty and responsibility of any person receiving a permit to:

- A. Pay a permit fee in an amount established by resolution of the Township Commissioners.
- B. Make a deposit to cover any additional costs borne by the Township, specifically inspection related to the work authorized by the permit. The amount of such deposit shall be computed by the Township Secretary as provided in §592-18 of this Article. In the case of public utility companies, the Township may waive the requirement of a deposit if said utility companies file with the Township their corporate bond in a form satisfactory to the Township Solicitor, conditioned upon the payment to the Township of all costs which would otherwise be covered by and paid out of such a deposit. In the event that such utility companies elect to file such a bond, the Township shall bill such utility companies monthly for such costs as they accrue.
- C. Pay a restoration guarantee fee equivalent to the schedule as stated in any fee calculation determined by the Commissioners of the Township of Stowe. Pavement replacement shall be calculated as surface area, curb to curb and 25 feet from each end of the utility opening multiplied by a cost set forth on the application. Said cost as established by the Township Board of Commissioners by resolution for future milling and resurfacing by the Township.

§ 592-26 – Display of permit.

The contractor or person doing the work of opening or excavating as aforesaid shall, at all times, maintain in his possession and shall exhibit to any official of said Township upon demand the merit to do the said work, which permit only shall be evidence of authority for doing the same.

§ 592-27 – Regulations for Openings and Excavations

- A. No opening or excavation in any street shall extend beyond the center line of the street before being backfilled and the surface of the street temporarily restored.
- B. No more than 100 feet measured longitudinally shall be opened in any street at any one time, except by special permission of the Township Secretary of Stowe.
- C. Cuts to improved roadway and/or sidewalks shall be made using straight, saw cut edges.
- D. Work shall comply with PennDOT Specifications Form 408 for all work not specified herein.
- E. All utility facilities shall be exposed sufficiently or their definite location shall be determined ahead of trench excavation work to avoid damage to those facilities and to permit their relocation, if necessary.
- F. Pipe drains, pipe culverts or other facilities encountered shall be protected by the permittee. The permittee shall immediately notify the Township and the utility or facility owner should existing facilities need relocated, protected or are damaged by the permittee's operations.
- G. Any person whose facilities are damaged or caused to be relocated by the permittee shall notify the permittee and the Township of such damage thereafter may make the necessary repairs or relocation and file a claim against the permittee with the Township for the cost of such repairs or relocation. Public utility companies concerned shall be notified by the Township in sufficient time to determine the validity of the damage or relocation claims. The cost of such repair work or relocation work may be withheld by the Township Secretary from the deposit pending determination of liability for the damage.
- H. Monuments of concrete, iron or other lasting material set for the purpose of locating or preserving the lines of any street or property subdivision or a precise survey reference point or a permanent survey benchmark within the Township shall not be removed or disturbed or caused to be removed or disturbed unless permission to do so is first obtained, in writing, from the Township. Permission shall be granted only upon the condition that the permittee shall pay all expenses incident to the proper replacement of the monument.
- I. When work performed by the permittee interferes with the established drainage system of any street, provision shall be made by the permittee to provide proper drainage.
- J. When any earth, gravel or other excavated material is caused to flow, roll or wash upon any street, the permittee shall cause removal of the same from the street within 8 hours after deposit to permit safe flow of traffic. In the event that the earth, gravel or other excavated material so deposited is not removed as specified, the Township Secretary shall cause such removal, and the cost incurred shall be paid by the permittee or deducted from his or her deposit.

- K. Every permittee shall place around the project such barriers, barricades, lights, warning flags and danger signs as shall be determined by the Department of Public Works/Township Secretary to be necessary for the protection of the public. Additional safety requirements may be prescribed by the Township Secretary and, where applicable, shall be in conformance with the requirements set forth in 67 Pa. Code, §203.1 et seq., as amended, dealing with work zone traffic control. Copies of the publication shall be made available in the office of the Township Secretary for inspection by the public.
- i. Whenever any person fails to provide or maintain the required safety devices, such devices shall be installed and maintained by the Township. The amount of the cost incurred shall be paid by the permittee or deducted from his or her deposit.
 - ii. No person shall willfully move, remove, injure, destroy or extinguish any barrier, warning light, sign or notice erected, placed or posted in accordance with the provisions of this Section.
 - iii. Access to private driveways shall be provided except during working hours when construction operations prohibit provision of access. Free access must be provided to fire hydrants at all times.
- L. Access to private driveways shall be provided except during working hours when construction operations prohibit provision of such access. Written notification must be provided to affected property owner and Township 5 days in advance of work by the contractor.
- M. Excavated materials shall be laid compactly along the side of the trench and kept trimmed up so as to cause as little inconvenience as possible to public travel. In order to expedite the flow of traffic or to abate dirt or dust nuisance, the Township Secretary may require the permittee to provide boards or bins; and if the excavated area is muddy and causes inconvenience to pedestrians, temporary wooden plank walks shall be installed by the permittee as directed by the Township of Stowe.
- N. Unless the street opening is backfilled the same day, all dirt or other debris removed from the opening shall be hauled away. In no case shall any excavated material remain onsite beyond that day's work period.
- O. Work authorized to be performed by a permittee shall be performed between the hours of 7 a.m. and 7 p.m., Monday through Friday, unless the permittee obtains written consent from the Township Secretary to do the work at an earlier or later hour. Such permission shall be granted only in the case of any emergency or in the event that the work authorized by the permit is to be performed in traffic-congested areas. The work shall not interfere with any public transportation or school bus transportation without obtaining prior written approval from the affected entity.
- P. In granting any permit, the Township may attach such other conditions thereto as may be reasonably necessary to prevent damage to public or private property or to prevent the operation from being conducted in a manner hazardous to life or property or in a manner likely to create a nuisance. Such conditions may include, but shall not be limited to:

- i. Limitations on the period of the year in which the work may be performed.
 - ii. Restrictions as to the size, weight and type of equipment.
 - iii. Designation of routes upon which materials may be transported.
 - iv. Designation of the place and manner of disposal of excavated materials.
 - v. Daily requirements as to the laying of dust, the cleaning of streets, the prevention of noise and other results offensive or injurious to the neighborhood, the general public or any portion thereof.
 - vi. Regulations as to the use of streets in the course of the work.
- Q. Hydra-hammer, headache ball. The use of a mechanical devise for the breaking of pavement, such as a hydra-hammer, headache ball, etc., will be permitted only under special written permission of the Township of Stowe.

§ 592-28 – Backfilling and Restoration.

- A. All pavement cuts, openings, and excavations shall be made properly and backfilled properly by the permittee according to Township specifications, including but not limited to the details attached hereto and incorporated herein Appendix A to this Chapter. If weather conditions are such as to prevent the completion of permanent restoration of the street surface at the time backfilling is completed, the permittee shall install a temporary surface in accordance with municipal specifications until such time as weather conditions will permit permanent restoration of the street surface.
- B. The Township Secretary and Department of Public Works shall be notified by the permittee a minimum of 72 hours in advance of backfilling and restoration to provide adequate time to schedule an inspection. Such notice shall provide the approximate time each will begin.
- C. No backfilling or restoration shall be accomplished unless or until the Department of Public Works or a designated Township Representative is present or permission has been granted for backfilling or restoration after inspection by the Department of Public Works or the designated Township Representative.
- D. If the Township of Stowe finds that paving surfaces adjacent to the street openings may be damaged where trenches are made parallel to the street or where a number of cross trenches are laid in proximity to one another or where the equipment used may cause such damage, it is required that the permittee correct and return the disturbed area to its pre-disturbed condition.
- E. After excavation has commenced, the work of making and backfilling the same shall be prosecuted with due diligence. The permittee is required to complete permanent restoration of the street surface in accordance with Township specifications within 7 days after repairs and/or installation are completed. Furthermore, the permittee shall be required to install and maintain a temporary surface in accordance with Township specification during:

- i. The period between the completion of repairs and/or installation and the commencement of final restoration.
 - ii. The periods during the actual work when workers do not require access to the excavation.
- F. Inspections of all work authorized by a permit shall be made by the Department of Public Works and/or the Township Engineer at such times and in such manner as required to assure compliance with provisions of this Article. If the nature of the work to be performed under any permit is such as to require the services of a full-time inspector, the Township Secretary shall provide for the services of such inspector.
- G. All costs of inspection shall be borne by the permittee. Such costs shall be based upon a schedule of charges on file in the offices of the Township.
 - i. If any settlement in a restored area occurs within a period of 2 years from the date of completion of the permanent restoration and the permittee fails to make such correction after notification, any expense incurred by the Township in correcting such settlement shall be paid by the permittee or recovered from his or her bond, unless the permittee submits proof, satisfactory to the Township Secretary, that the settlement was not due to defective backfilling.
- H. In no case shall any opening made by a permittee be considered in the charge or care of the Township or any of its officers or employees, and no officer or employee of the Township is authorized in any way to take or assume any jurisdiction over any such opening, except in the exercise of the police power when it is necessary to protect life and property.
- I. The permittee is responsible for the full restoration of the roadway surface or sidewalk, including re-stripping, installation of raised pavement markings, speed bumps and signage, etc.
 - i. On concrete-base streets, such base shall be replaced with concrete.
 - ii. New streets
 - a. If it is sought to excavate upon or open a sewer within five years after the completion of paving on a Township street, the applicant shall make written application to the Township Board of Commissioners, and a permit for such opening shall be issued only after express approval of the Township's Board of Commissioners except in cases of emergency.
 - b. In the event that the newly paved or resurfaced street is dedicated to the Township, the sixty-month period shall be deemed to begin on the date of acceptance.
 - c. The new street surface shall be permanently restored as specified in the

Township specifications in Appendix A.

- d. All final restorations shall have saw-cut edges to the limits of milling.
- e. Prior to the installation of the final wearing course, all vertical edges shall be tack-coated with asphalt cement class PG 64-22 and in accordance with PennDOT Specifications Publication 408.

§ 592-29 – Emergency work.

- A. It shall be unlawful for any person to make any tunnel, opening or excavation of any kind in or under the surface of any street without first securing a permit from the Township of Stowe for each separate undertaking.
- B. Any person maintaining pipes, lines, or other underground facilities in or under the surface of any street may proceed with an opening without a permit when emergency or unforeseen circumstances demand the work to be done immediately, provided that the permit could not have reasonably and practically been obtained beforehand. In such cases where emergency openings are necessary, the Township shall be notified prior to such openings by either fax (PA 1-Call) or telephone. The person shall thereafter apply for a permit on the first regular business day on which the office of the Township of Stowe is open for business, and said permit shall be retroactive to the date when the work was begun.

§ 592-30 – Inspection of work

All work done under the authority of any permit shall be supervised and inspected by the Township Ordinance Officer and/or the Township Engineer. Such supervision and inspection shall be done at the sole expense of the applicant. The Township Ordinance Officer and/or the Township Engineer shall have the right to inspect and supervise all work done under street opening permits and shall see that all the terms and provisions of this article are enforced. The Township Ordinance Officer and/or the Township Solicitor shall have the proper to prosecute every person, firm, or corporation violating any of the provisions contained herein.

§ 592-31 – Deposits

- A. Computation of Deposit. The Township, upon receipt of a properly completed application,

shall determine the amount of the deposit to be made by the permittee in accordance with the schedule of charges established pursuant to subsection 5 of this Section; provided, however that the minimum deposit required shall not be less than \$500. The deposit shall be paid at the time the permit is issued, and the deposit shall be used to reimburse the Township for the cost of any work and/or materials furnished by it in connection with work authorized by the permit, to cover the cost of all necessary inspections of said work or any other expenses incurred by the Township in carrying out the provisions of this Part. In the case of a public utility company, the requirement of such deposit may be waived if such public utility company files with the Township its corporate bond as provided in § 592-12B. of this Article.

- B. Form of Deposit. The deposit may be either in the form of a certified, treasurer's or cashier's check. Personal checks will be accepted and permit will be accepted once the check has cleared.
- C. Insufficient Deposit. If any deposit is less than sufficient to pay all costs, the permittee shall, upon demand, pay to the Township an amount equal to the deficiency. If the permittee fails or refuses to pay such deficiency, the Township may institute an action to recover the same in any court or competent jurisdiction. Until such deficiency is paid in full, no additional permits shall be issued to such permittee.
- D. Yearly Deposit. Whenever any public utility company shall anticipate applying for permits for more than one street opening or excavation per calendar year and does not elect to file a corporate bond as hereinbefore provided, such public utility company may post one deposit in an amount and form as hereinbefore provided for that calendar year or part thereof to cover the cost of deposits which would otherwise be required for the anticipated permits.
- E. Deposit and Cost Schedules. Yearly resolution shall establish a schedule of charges for inspections, labor, materials and other such expenses as may be incurred by the Township in carrying out the provisions of this Part. This schedule shall be established by the Township Secretary in accordance with the reasonably anticipated costs to be incurred by the Township making such inspections, including reasonable administrative and overhead expenses, and in accordance with the currently prevailing costs in the area for any labor and materials which may be provided by the Township. The Township Secretary shall revise said schedule from time to time to reflect any increase or decrease in the costs used to establish said charges. The schedule shall be open to public inspection in the office of the Township upon request.
- F. Decision on Costs. The decision of the Township Secretary as to the cost of any work done or repairs made by him or her under his or her direction, pursuant to the provisions of this Part, shall be final and conclusive as to such cost, subject to such rights of appeal as may exist by statute.

- G. **Refund of Deposit.** Upon notification by the permittee that all work authorized by the permit has been completed, and after restoration of the opening, the Township Secretary shall refund to the permittee his or her deposit, less all cost incurred by the Township in connection with said permit. In no event shall the permit fee be refunded.

§ 592-32 – Bond Requirements.

- A. **Performance Bond:** Each applicant or permittee, upon receipt of a permit, shall provide the Township with financial security, in a form acceptable to the Township Solicitor and in compliance with the requirements of this Part to guarantee faithful performance of the work authorized by a permit granted pursuant to this Part. The amount of the financial security shall be equivalent to the restoration guarantee schedule as stated in the fee calculation. The term of the financial security shall begin upon the date of depositing thereof and shall terminate upon the receipt by the permittee of a certificate of final inspection from the Township Secretary. If the permittee anticipates requesting more than one permit per year, as required by this Part, he or she may furnish a single financial security to guarantee faithful performance in such amount as the Township Secretary deems necessary. The amount of such bond shall be in relation to the cost of restoring pavement cuts to be made by the permittee throughout the year. In the case of a public utility company, its corporate bond, in a form satisfactory to the Solicitor, may be accepted in lieu of the corporate bond surety required by this Section and the requirements of this Part.
- B. **Maintenance Bond:** Each applicant, upon the receipt of a permit, shall provide the Township with financial security, in a form acceptable to the Township Solicitor and in compliance with the requirements of this Part to guarantee the maintenance of the work authorized by a permit granted pursuant to this Part, as well as compliance with the street opening specifications of the Township and the provisions of this Part. The Township Secretary and or Township Engineer shall determine the amount of the bond, and it shall be in relation to the cost of restoring the pavement cut to be made by the permittee; provided, however, that the minimum amount of the bond shall not be less than \$2,000. The term of each bond shall begin from the completion date of the permanent restoration of the opening by the Township and shall terminate upon the receipt by the permittee of a certificate of final inspection from the Township Secretary. If the permittee anticipates requesting more than one permit a year, he or she may file a single financial security to guarantee maintenance of the work authorized by a permit granted under this Part, as well as compliance with the specifications of the Township and the provisions of this Part, in such amount as the Township Secretary deems necessary. The amount of such bond shall be in relation to the cost of restoring pavement cuts to be made by the permittee throughout the year. In the case of a public utility company, its corporate bond, in a form satisfactory to the Solicitor, may be accepted in lieu of the corporate surety bond required by this Section and the requirements of this Part.

- C. Default in Performance: Whenever the Township of Stowe shall find that a default has occurred in the performance of any term or condition of the permit, notice thereof shall be given to the principal and to the surety on the bond. Such notice shall state the work to be done, the estimated cost thereof and the period of time deemed by the Township of Stowe to be reasonably necessary for the completion of such work.

- D. Completion of Work: After receipt of such notice, the surety must, within the time therein specified, either cause the required work to be performed or, failing therein, indemnify the Township for the cost of doing the work as set forth in the notice.

§ 592-33 – Liability Insurance

Each applicant, upon the receipt of a permit and prior to performing work under the permit, shall procure and maintain adequate insurance in an amount of at least \$1,000,000 to protect it from claims for damages because of bodily injury, including death, and from claims for damages to property which may arise out of or be related to the performance of work under the permit, whether such performance is by the applicant or the applicant's subcontractor or anyone directly or indirectly employed by the applicant. Such insurance shall cover collapse, explosive hazards, underground work and work by equipment on the street and shall not include protection against liability arising from completed operations. The specific amount of the insurance shall be prescribed by the Township Secretary in accordance with the nature of the risk involved; provided, however, that the liability insurance for bodily injury and property damage shall be in an amount not less than \$1,000,000 per occurrence and \$1,000,000 aggregate. A certificate of insurance, in the amount required by this Section and in a form acceptable to the Township Solicitor, shall be filed with the Township Secretary prior to commencement of work under the permit. This certificate of insurance shall also state that the Township shall be given written notice at least 60 days prior to cancellation of such insurance. The Township shall be listed as an additional insured and/or loss payee on all policies of insurance described in this Section. Public utility companies and authorities may be relieved of the obligation of submitting such a certificate if they submit satisfactory evidence, in a form acceptable to the Township Solicitor, that they are insured in accordance with the requirements of this Part or have adequate provision for self-insurance. Public utility companies may file an annual certificate of insurance in lieu of individual certificates for each permit.

§ 592-34 – Abandoned Facilities.

- A. Whenever any pipe, conduit, duct, tunnel or other structure located under the surface of any street is abandoned or the use thereof is abandoned, the person owing, using, controlling or having an interest therein shall, within 30 days after such abandonment, file

with the Township Secretary a statement, in writing, giving in detail the location of the structure so abandoned. Whenever there are manholes or tunnels associated with any abandoned underground facilities, such manholes or tunnels shall be filled in at the time of abandonment and the Township Secretary notified thereof in writing.

- B. When the Township plans to pave or improve streets in which there are abandoned facilities, the owner of such facilities shall be notified to remove them if, in the opinion of the Township Secretary, their removal is in the best interest of the Township. If the owner shall refuse to remove such abandoned facilities, the Township shall remove the abandoned facilities and the owner shall reimburse the Township for such removal.

§ 592-35 – Notice to Abutting Owners and Tenants.

- A. If the work to be undertaken by the permittee is such that it will affect the use of properties abutting or adjoining the project, the Township of Stowe may require the permittee to submit a list of owners and/or tenants and/or addresses of all properties abutting the area where the work authorized by the permit is to be performed. Upon receipt of such list, the Township Secretary shall notify the affected property owners and/or tenants of the proposed work to be done.
- B. If the work to be undertaken by a permittee will affect other subsurface installation(s) in the vicinity of the proposed opening, the contractor shall notify the owner(s) of such facilities of the proposed work.

§ 592-36 – Notice to Police and Fire Authorities.

The Township Secretary shall notify, in writing, Township police and fire authorities of all street opening permits he or she grants of a nature that would require a street being closed. Such notification shall state the nature of the work to be done, the proposed beginning and completion dates and the location of each project.

§ 592-37 – Violations and Penalties.

- A. Any person, firm or corporation who violates a provision of this Part, or who fails to comply therewith, or with any of the requirements thereof, shall be, upon conviction thereof, sentenced to pay a fine up to \$1,000 for each violation, plus costs, and, in default

of payment of said fine and costs, to imprisonment to the extent permitted by law for the punishment of summary offenses.

- B. A separate offense shall arise for each day or portion thereof in which a violation is found to exist or for each Section of this Part found to have been violated. All fines and penalties for the violation of this Part shall be paid to the Township Treasurer.
- C. The Township may also commence appropriate actions in equity, at law or other to prevent, restrain, correct, enjoin, or abate violations of this Part.

Section 2. Ordinance 1014, Chapter 592, Article IV, Sections 592-29 through 592-32 shall be amended as follows, and shall be renumbered to be Sections 592-38 to 592-41. The text of each respective section shall remain the same.

Section 592-29 (“Public Safety”) shall now be renumbered to be Section 592-38;

Section 592-30 (“Definitions”) shall now be renumbered to be Section 592-39;

Section 592-31 (“General Provisions”) shall now be renumbered to be Section 592-40;

Section 592-32 (“Liability”) shall now be renumbered to be Section 592-41.

Section 3. Repealer:

All ordinances or resolutions or parts of ordinances or resolutions insofar as they are inconsistent herewith are hereby repealed and rescinded.

Section 4. Severability:

If any part of this Ordinance is for any reason found to be unconstitutional, illegal or invalid, such part of the Ordinance shall not affect or impair any of the remaining portions of this Ordinance.

Section 5. Effective Date:

This Ordinance shall become effective immediately, or as otherwise provided by the laws of the Commonwealth of Pennsylvania.

ORDAINED AND ENACTED into law this 12th day of May, 2020.

ATTEST:

By: 
Nicholas Martini
Township Secretary

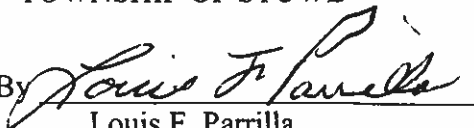
TOWNSHIP OF STOWE
By: 
Louis F. Parrilla,
Chairman, Board of Commissioners